

Drinks Machine - 1

ACTIVITIES

These materials present a series of activities for **building your own programs** to control the Drinks Machine Soft System. Together, they build into a complete control system for the drinks machine.

Skills - You need to know how to:

- Switch outputs (including motors) on and off in a timed sequence;
- Monitor both digital and analogue input devices and produce an output in response;
- Use procedures as building blocks to build a larger program.

These skills are taught in the teaching materials for the: Pelican Crossing, Car Park, Burglar Alarm, and Greenhouse.

From the **System> Soft Systems** menu, select **Drinks Machine**

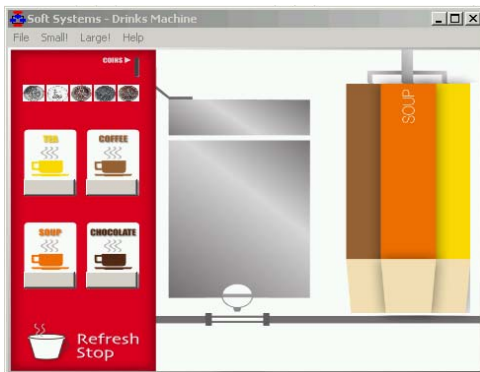

From the Soft System window menu, select **Help>Quick Help**

Look through this carefully to see what input and output devices there are in this system.

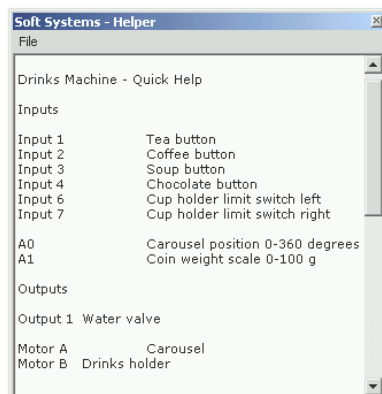

Activity One



Build your own program to control the drinks machine to this specification:

Specification One



The program must carry out the following sequence just once:

1. Move the cup holder to the carousel. A cup will automatically drop into the holder.



Move the cup back under the valve.



2. Fill the cup with water.



It takes approximately 1.5 seconds to fill the cup. When the cup is full, the user must click on it to remove the drink.

3. When the cup is full, display a message for 3 seconds, telling the user to take the drink. See Logicator Help for information on using the **Message** command.

Drinks Machine - 2

Activity Two



Each one of the four sections of the carousel holds cups containing powder for one of the four different drinks. There is a sensor (A0) on the carousel that checks how far it turns, and gives a reading in degrees for each of the drinks:

Coffee	A0 = 0°
Soup	A0 = 90°
Tea	A0 = 180°
Chocolate	A0 = 270°

Build and test a separate procedure for each one of the four drinks, using the following specification:

Specification Two

Turn the carousel to the section for that drink. Stop the carousel. Then collect a cup from the carousel, and fill it.

Help

Use this pattern for each procedure.

When you have tested a procedure, remember to click on the cup to remove it, before you test another one.

If you try to fill an already full cup, it will overflow.

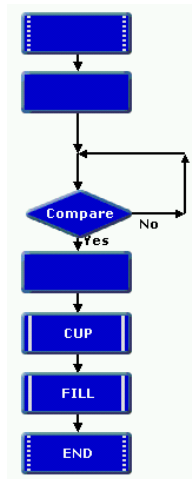

Activity Three

The drinks machine has four “select drink” buttons:

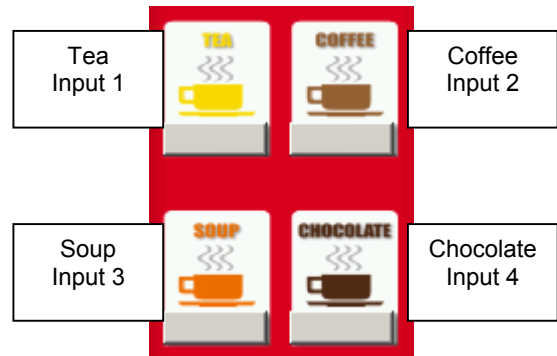

Add a new procedure to your program that checks all four of these digital inputs and does the correct drink procedure when one of the buttons is pressed.

Help

Use this pattern for the new procedure:

When you run the procedure, keep the button pressed until you see the carousel move.

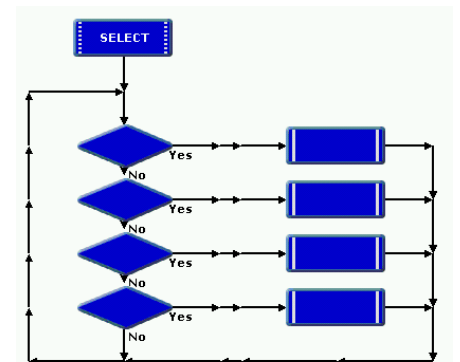

Activity Four

Finally, build the main routine for the program as shown here:

The program must also contain all the procedures you have built in Activities One, Two and Three.

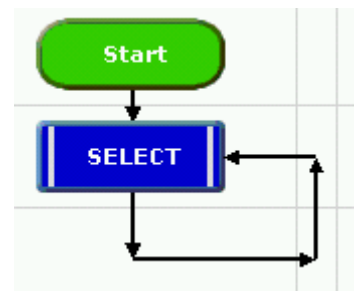

You should now have a complete control system for the drinks machine – although all the drinks are free! The next section shows how to include a system to make users pay for their drinks.

Drinks Machine - 3

Activity Five – Paying for drinks

You can click on a coin symbol to insert that coin into the machine.



Sensor A1 weighs the coin. The weights of each coin are shown in the Soft System Quick Help panel.

Specification Three

The machine must check if a coin is inserted. It must then record the value of the coin. If 25p or more has been inserted, the machine must enable the user to select a drink.

If the money inserted is enough for more than one drink, the machine must allow more drinks to be selected until the money is used up.

You could try developing this part of the system for yourself, or use the following instructions to add it to your program.

1. Extend the main routine as shown below:

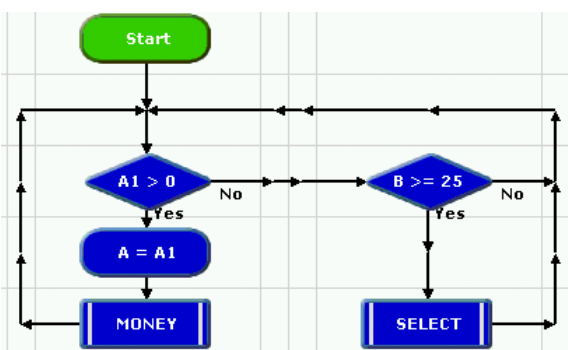

The Compare command $A1 > 0$ checks to see if a coin has been inserted. The Expression command $A = A1$ records the weight of the coin in variable A (A1 resets to 0 as soon as the coin leaves the weighing platform).

The Compare command $B \geq 25$ checks to see if the user has inserted 25p or more. If so, the SELECT procedure runs, allowing them to select a drink

The MONEY procedure checks the weight of the coin (A) and adds the value of the coin, in pence, to the variable B which is used to keep a record of the user's credit.

2. Build the MONEY procedure as shown below.

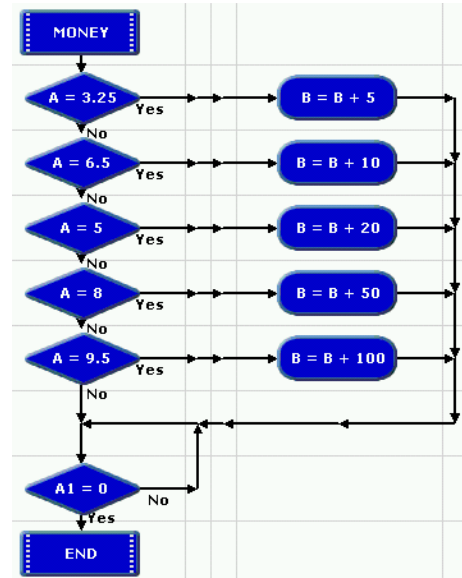

3. Finally, the system must deduct 25p from the user's credit (B) after a drink has been delivered. So add the Expression command $B = B - 25$ to the end of the SELECT procedure.

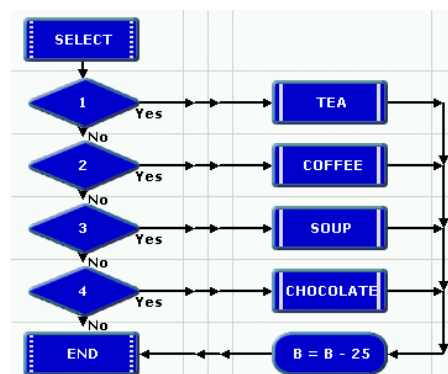

Extension

Use Message commands to add the following features to your drinks machine system.

Specification Four

Provide a constant display of the user's credit.

Inform the user when a drink has been selected.